

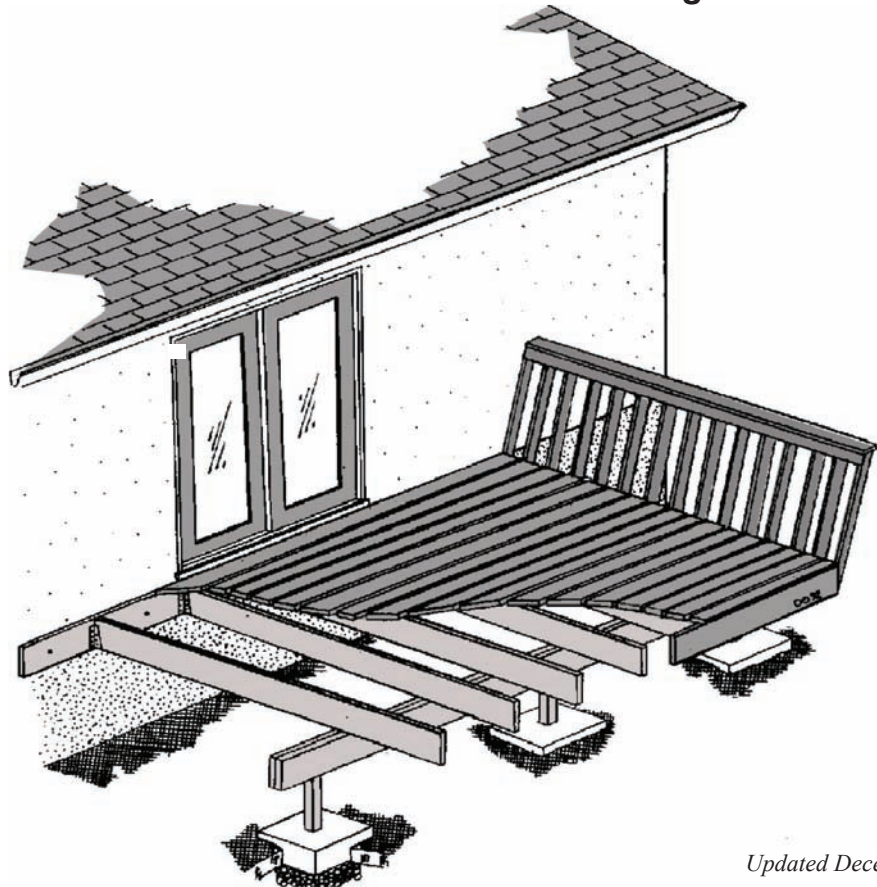

PLANNING AND ZONING
DEPARTMENT

Wood Decks

*Zoning and Construction
requirements for open
non-sheltered wood decks
for residential dwellings.*



Updated December 2023

General Information _____	3
Zoning _____	7
Foundations _____	8
Structural _____	11
Design _____	15
Compliance _____	19

Note

The City of Steinbach Building By-law is primarily an administrative document that adopts the Manitoba Building Code and related standards to provide construction requirements. Throughout this booklet the Manitoba Building Code will be referred to as the Building Code.

Decks vary in size and area and it is beyond the scope of this publication to deal with each possible situation. The requirements and construction guidelines that follow are provided to assist you in designing and constructing a deck.

Every effort has been made to ensure the accuracy of information contained in this publication. However, in the event of a discrepancy between this booklet and the governing City of Steinbach By-law, the By-law will take precedence.

Do I require a building permit for a deck?

Yes! A building permit is required for any deck which is higher than 600 mm (24 in.) above average ground level or ANY deck which will eventually support an enclosed structure with a roof such as a sun room, family room, etc.

What if the deck is not attached to my house, do I still need a building permit?

Regardless of whether or not the deck is attached to the house or any other structure on the property, a building permit is required, as noted above.

Where can I obtain a building permit?

Permits may be obtained by submitting the required information to the Planning and Zoning Department at City Hall, 225 Reimer Avenue, Steinbach or online at www.steinbach.ca.

Are overhead power supply conductors or Hydro meters a cause for concern?

YES! If you plan to build a deck beneath overhead power supply conductors, a minimum clearance of 3.5 m (11 ft. 6 in.) must be maintained between the deck surface and the conductors. If the deck is to be installed beneath a Hydro meter, it may be necessary to relocate the meter to maintain the proper meter height. For more information contact your local Manitoba Hydro District Operating Centre at the phone number listed on your Manitoba Hydro bill.

What information do I have to provide in order to make application for a building permit?

1. You must present one copy of a Surveyor's Building Location Certificate. As an alternative, a well drawn site plan showing all property dimensions, location of all buildings, and the location and size of the proposed deck may be acceptable. See FIGURE 1 for details.
2. One (1) copy of the construction and elevation plan is required. This plan details how the deck will be constructed.
3. Fill out the Wood Deck Construction Checklist, available on www.steinbach.ca.

FIGURE 1 - Typical Site Plan

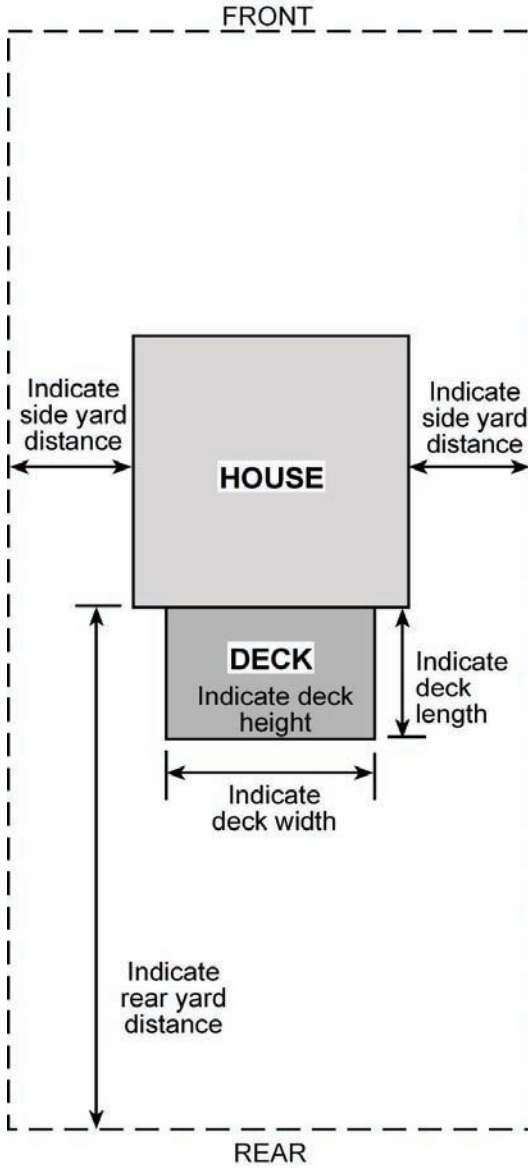

What do the construction and elevation plans have to indicate?

The construction plans must show the overall size of the deck, the size and spacing of the beams, posts, and deck joists, the species and grade of the wood material being used, (eg. SPF #2; species - spruce, grade - #2) the type of foundation you have chosen to support the deck and the location of any stairs leading to or from the deck. See FIGURE 2.

The elevation plan must show the height of the deck floor above finished ground level at its highest point and the height and type of guardrail being used around the perimeter of the deck. See FIGURE 3.

FIGURE 2 - Typical Construction Plan

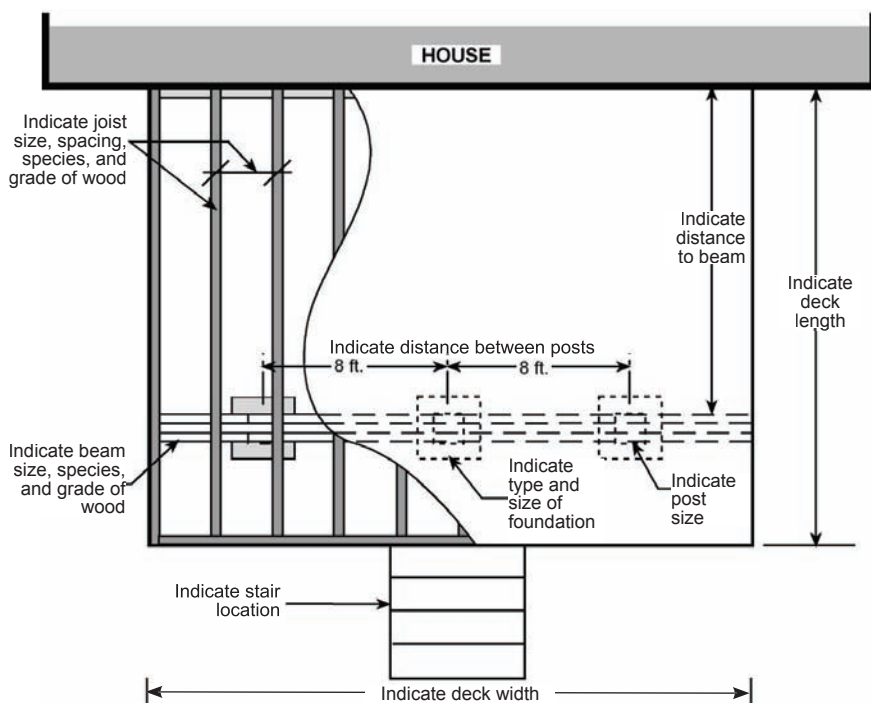
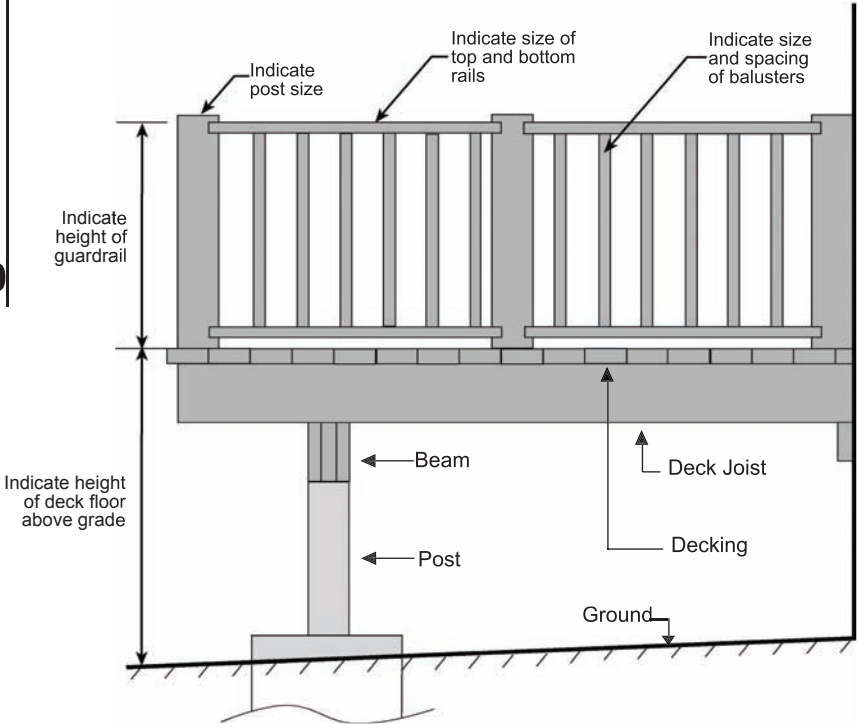

FIGURE 3 - Typical Deck Elevation Plan



Where and how high can I build my deck?

As indicated in FIGURE 4, zoning requirements on the height of the deck will determine its location.

If I cannot meet the zoning requirements, what are my alternatives?

To vary these requirements you must apply for a Zoning variance. This application can be made at City Hall at 225 Main Street. Note: There are fees associated with a zoning variance application.

FIGURE 4 - Deck Location

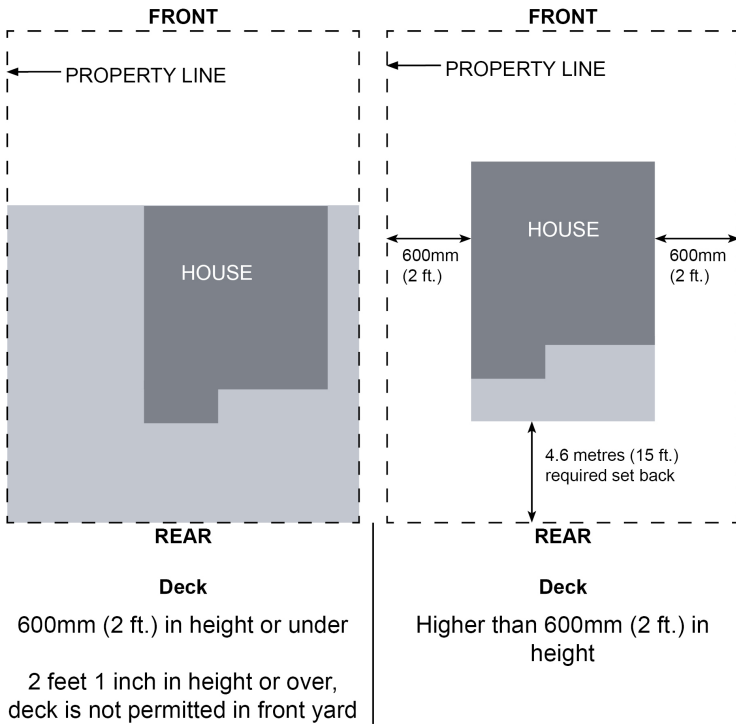

OPEN DECKS UNDER 1800 MM (6 ft.) IN HEIGHT

Surface Pad Foundations

Surface pad foundations are only permitted when an open deck is

- a) not more than one storey;
- b) not more than 55m² (592 ft²) in area;
- c) not more than 1800 mm (6 ft.) in distance from finished ground to top of decking;
- d) not supporting a roof, and
- e) not attached to another structure, unless it can be demonstrated that differential movement will not adversely affect the performance of that structure, as determined by the authority having jurisdiction.

When using surface foundations, access must be provided to the foundation to permit re-levelling of the deck platform. It can be provided either by:

- a) a passageway with a clear height and width under the deck platform of not less than 600 mm (2 ft); or
- b) by installing the decking in a manner that allows easy removal (eg. screws)

What are the recommendations for a surface pad foundation?

Surface pads of concrete shown in FIGURE 5 should be a minimum of 75 mm (3 in.) thick. Wood posts and/or wood beams closer than 150 mm (6 in.) to the ground must be pressure-treated preservative lumber to prevent the premature deterioration of the post or beam, which will be bearing on the pad.

Refer to TABLE 1 to determine the recommended size of the surface pad foundation. These pad sizes are based on existing industry standards and are generally available at most lumber or home supply dealers.

FIGURE 5 - Surface Pad Foundation

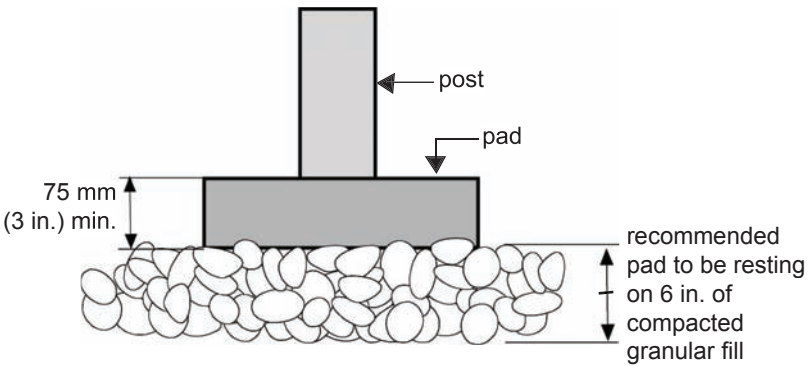

TABLE 1 - Recommended Deck Foundation Pad Sizes⁽¹⁾

Maximum Supported Joist Length ⁽²⁾	Concrete Surface Pad Size ⁽³⁾ (length x width x thickness)
1.22 m (4 ft.)	300 mm x 300 mm x 100 mm (12 in. x 12 in. x 4 in.)
2.45 m (8 ft.)	450 mm x 450 mm x 75 mm (18 in. x 18 in. x 3 in.)
3.65 m (12 ft.)	600 mm x 600 mm x 150 mm (24 in. x 24 in. x 6 in.)

Notes to TABLE 1:

- 1) This table requires beams that are supported every 2.44 m (8 ft.) or less.
- 2) Supported joist length means half the span of joists supported by the beam plus the length of the overhang beyond the beam. (See FIGURE 8)
- 3) Pad sizes are based on industry standards.

Can a pergola or a trellis type structure be added to a deck on pads?

No. A deck on pads is not permitted to support any additional structures. If your long term goal is to enclose all or a portion of your deck with a trellis, a screened in area or a sunroom, it is suggested that you use a pile or pier foundation.

OPEN DECKS OVER 1800 MM (6 ft.) IN HEIGHT Pile

or Pier Foundations

When the top of the decking is more than 1800 mm (6 ft) above the ground, the foundation depth must be at least the depth of frost penetration - 1.8 m (6 ft.). A pier or pile type foundation, as shown in FIGURE 6, or alternatively a foundation designed by a Professional Engineer is required.

FIGURE 6 - Piles or piers

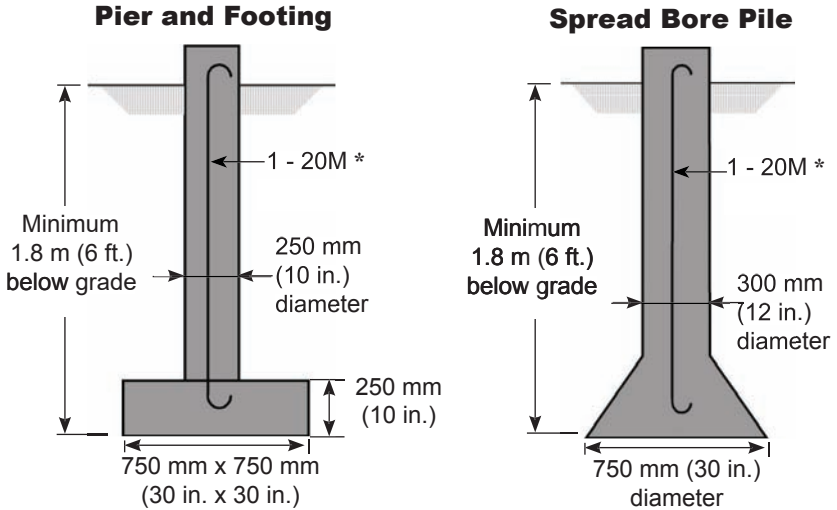

* refers to one 20 mm (#6) diameter reinforcing bar

What other options are available?

A foundation using “ground anchors” may be permitted providing the anchor extends to below the depth of frost penetration and has been properly tested. You may need to retain someone to do load calculations to determine that the loads transferred to the foundation does not exceed the loads for the tested anchors. If your future plans are to enclose the deck with a sunroom, screened patio, etc. the type of “ground anchors” must be approved for sunroom, screened patio, etc. uses.

How far apart can these pads, piles, or piers be installed?

The location of the pads, piles, or piers can vary depending on the size and type of material used for the beam that spans from one pad, pile, or pier to the other; and the amount of floor area that each individual pad, pile, or pier is required to carry.

The examples shown in FIGURE 7 are based on a beam that is supported a maximum 2.44 m (8 ft.) on centre. The beam table that follows indicates beams which are adequate for this spacing.

FIGURE 7 - Deck Beam Spacing

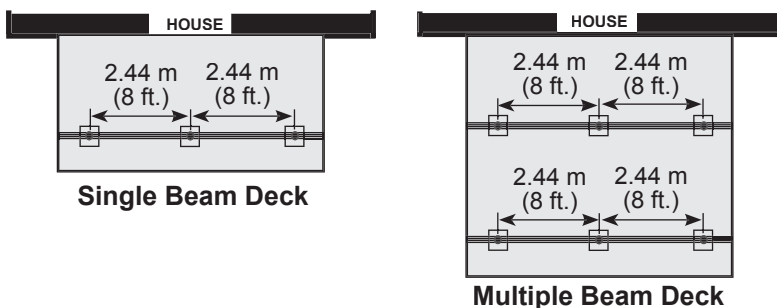

Can I vary from this 2.44 m (8 ft.) spacing?

The beam sizes indicated in this publication have been calculated by using common engineering principles. Other variations are possible provided the deck is designed and installed to carry a live load of 1.9 kPa (40 psf).

If you wish to increase the spacing of the pads, piles, or piers or if you wish to reduce the beam sizes indicated in the beam tables, you may have to retain someone who is familiar with engineering calculations. Whichever design you choose, it must be indicated on your plans at the time of your building permit application.

What size posts should I use and how should they be anchored?

Posts, if used, should be at least the width of the beam, centred on the pad, pile, or pier, and securely fastened to the beam by means of toe-nailing, wood gussets, angle brackets, or other equivalent method. Posts exceeding 1.5 m (5 ft.) in height should be braced to each other or up to the beam and floor or, alternatively, they should be anchored to the pad, pile, or pier in order to prevent them from shifting at the bottom.

What size of beams do I need?

The beam table (TABLE 2) is intended for single beam decks and multiple beam decks that is supported at 2.44 m (8 ft.) intervals along the beam. See also FIGURE 8.

**TABLE 2 - Deck Beam Sizes⁽¹⁾
- Design Floor Live Loads for 1.9 kPa (40 psf)**

Max. Supported Joist Length ⁽²⁾	Beam Size ⁽³⁾
6 ft.	3 ply 2x6 or 2 ply 2x8
8 ft.	4 ply 2x6 or 2 ply 2x8
10 ft.	3 ply 2x8 or 2 ply 2x10

Notes to TABLE 2:

- 1) This table requires beams to be supported every 2.44 m (8 ft.) or less.
- 2) Supported joist length means half the span of joists supported by the beam plus the length of the overhang beyond the beam. (See FIGURE 8.)
- 3) This table is for use with Spruce-Pine-Fir lumber grades 1 and 2.

FIGURE 8

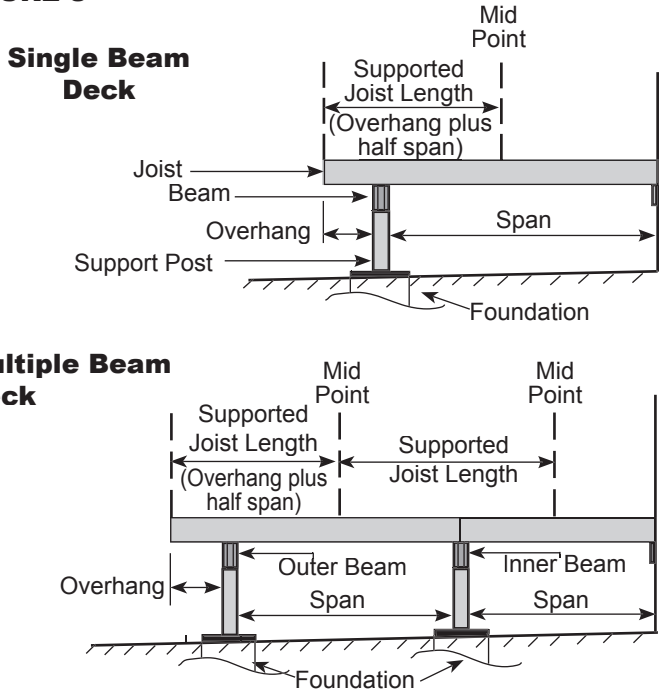

Can I have joints in the beam?

Yes. However, joints are ONLY permitted on multi-span beams. When joints are necessary, they should be situated on a support post. On multiple-ply laminated beams the joints should be staggered so that joints occur on alternate supports. If it is intended to project the beam beyond the end supports, there should be no joints on the end support.

How far can I project the beam beyond the end support?

The beam can project up to a maximum of 600 mm (2 ft.) beyond the end support. See FIGURE 10.

FIGURE 10

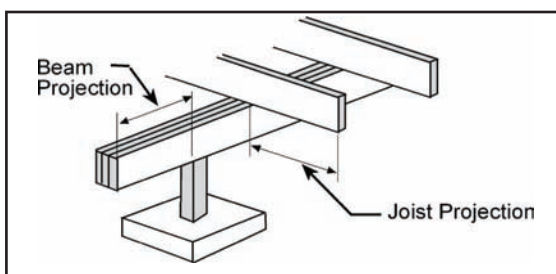

How should beam laminations be nailed together?

Individual members must be nailed together with a double row of nails at least 89 mm ($3\frac{1}{2}$ in.) in length, spaced not more than 450 mm (18 in.) apart in each row with the end nails located between 100 mm (4 in.) and 150 mm (6 in.) from the end of each piece.

How far can the joists project beyond the face of the outside beam?

If you are planning to eventually enclose all or a portion of the deck with a roofed structure which could carry snow, the Building Code states that the joists can only project 400 mm (16 in.) where 2x8 joists are used, and 600 mm (2 ft.) where 2x10 or larger joists are used. The projection of 2x4 or 2x6 joists would require engineering analysis to determine if the floor assembly would be sufficient to carry the superimposed roof loads. See FIGURE 10.

Note that even if you are not planning to enclose the deck in the future any projections beyond those indicated above would require engineering analysis.

What size of deck joists do I require?

The size of the joists are governed by the distance they have to span and the spacing at which the joists are installed. TABLE 3 indicates some common species and sizes of wood and the acceptable span distances for wood decks. Joist spans are measured from face of support to face of support (in the case of a wood deck from face of beam to face of beam, or from face of beam to face of ledger).

Another item you should take into consideration when selecting the type, size, and spacing of your joists, is the type of material you intend to use as decking. Check with your lumber dealer to ensure that the decking you select will not sag significantly between the joists as a result of the joist spacing you have chosen.

**TABLE 3 - Deck Joist Spans Incised*
- Design Live Loads for 39.7 psf**

Nominal Joist Size (in.)	Maximum Span (ft.-in.)				Maximum Allowable Cantilever (in.)	Joist Size (mm)	Maximum Span (m)				Maximum Allowable Cantilever (mm)
	Joist Spacing						Joist Spacing				
	8 in.	12 in.	16 in.	24 in.			200 mm	300 mm	400 mm	600 mm	
2 x 4	7-2	6-3	5-8	5-0	8	38 x 89	2.19	1.91	1.74	1.52	200
2 x 6	11-3	9-10	9-0	7-8	16	38 x 140	3.44	3.01	2.73	2.34	400
2 x 8	14-10	13-0	11-5	9-4	16	38 x 184	4.52	3.95	3.49	2.85	400
2 x 10	18-11	16-2	14-0	11-5	24	38 x 235	5.78	4.92	4.26	3.48	600
2 x 12	22-11	18-9	16-3	13-3	24	38 x 286	6.76	5.71	4.95	4.04	600

***Notes:**

1. Where guards are required, joists and rim boards shall be a minimum of nominal 2x8in. (38x84mm).
2. Spans are calculated for use of SPF No. 1 and No. 2 lumber; if other lumber is to be used, please consult with Building Official for maximum allowable spans.

Do the deck members need to be pressure treated?

When the vertical clearances between the wood elements and the finished ground level is less than 150 mm (6 in.) or when the wood elements are not protected from exposure to precipitation they must be pressure treated with a preservative to resist decay.

What is the difference between guardrails and handrails?

Guardrails are intended to prevent persons from falling off the edge of a stair or a raised floor area such as a deck. The guardrail must be able to withstand the pressure of a human body applied horizontally to it.

Handrails are required to assist persons in ascending or descending stairs. They offer a continuous handhold to support persons who may stumble on the stair.

Will my deck require guardrails?

Guards are only required on decks that are more than 600 mm (2 ft.) above finished ground level.

What if my deck is less than 600 mm (2 ft.) above finished ground level?

A guardrail is not required but, if one is provided, the openings through the guards have restrictions. These openings must either be less than 100 mm (4 in.) or greater than 200 mm (8 in.). This is to prevent children from accidentally getting their head stuck in the guard.

What are the construction requirements for a required guardrail?

- a) Required guardrails shall not be less than 900 mm (3 ft.) high where the walking surface of the deck is not more than 1800 mm (6 ft.) above the finished ground level, and 1070 mm (42 in.) high where the walking surface exceeds 1800 mm (6 ft.). (See FIGURES 11 & 12).
- b) Openings in the guardrail must prevent the passage of a spherical object having a diameter of 100 mm (4 in.)

FIGURE 11 - Guardrail Height

FIGURE 12 - Guardrail Height



Can a built-in bench serve as a guardrail?

No, unless a guardrail meeting the previously described height and opening requirements is provided above the flat surface of the bench and any openings below the bench also meet the maximum opening requirements. (See FIGURE 13)

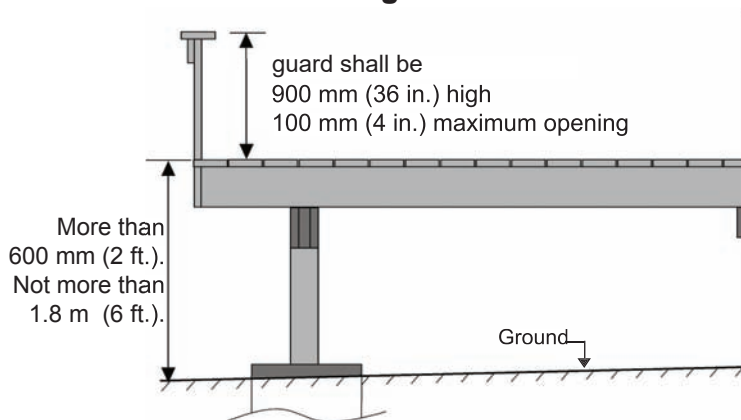
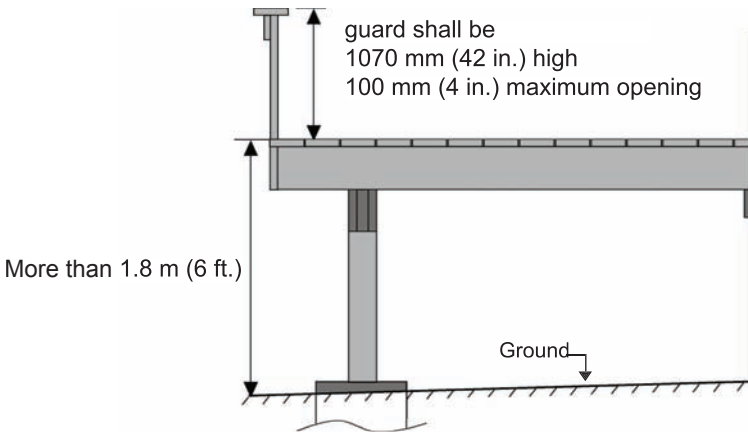
FIGURE 13 - Guardrail and Bench

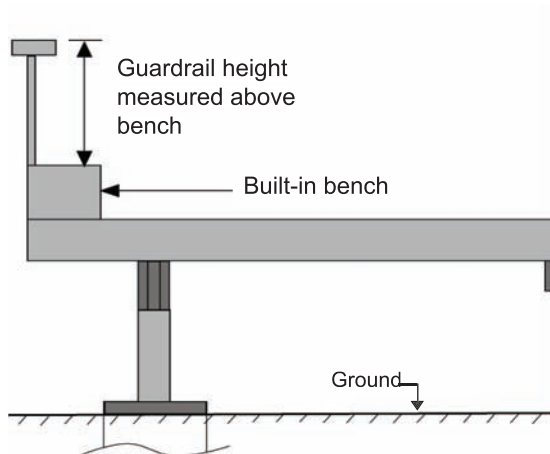

But what is the difference between a built-in bench and a chair or a table?

If a chair or a table are in a hazardous position you have the option of moving them. A built-in bench does not give you that option.

Are there any requirements for stairs?

The Building Code requires stair width to be at least 900 mm (36 in.) and that treads and risers have uniform rise and run in any one flight with riser heights not exceeding 200 mm (8 in.). The Building Code also requires the minimum run of each tread to be 255mm (10¹/₁₆ in.) and the minimum tread depth shall not be less than run, and not more than its run plus 25mm (1 in.). See FIGURE 14 for details.

FIGURE 14 - Stair Detail

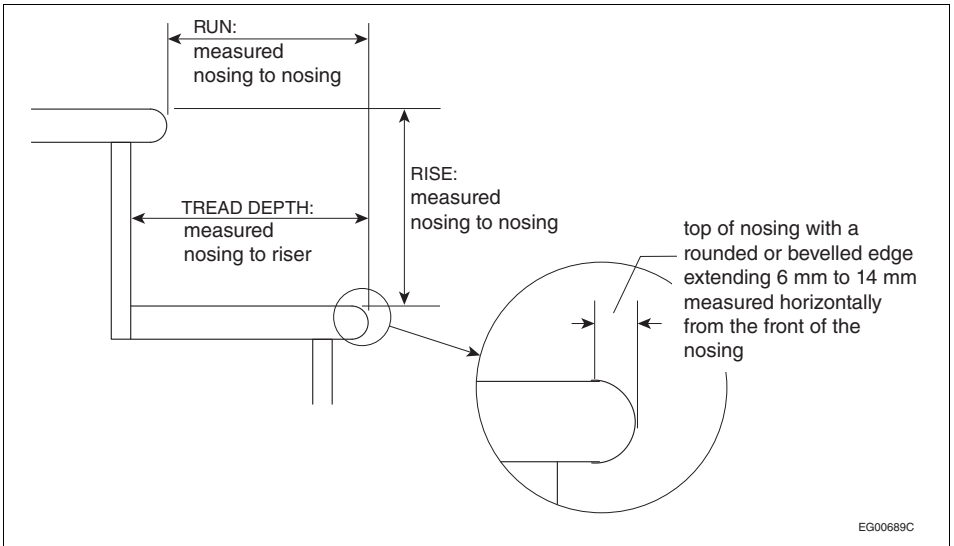

Are guardrails required for stairs?

Guards are required on stairs where there is a difference in elevation of more than 600 mm (2 ft) to finished ground level. The height of guards for flights of steps shall be 900 mm (3 ft.) and be measured vertically from the top of the handrail to a line drawn through the leading edge of the treads served by the guard. Guards shall be constructed in the same manner as indicated in sentence b) and c) under construction requirements for guards.

Will the stair also require a handrail?

The Building Code states that if any outside stair has more than three (3) risers, a handrail is required on one side of the stair. The handrail is to be located between 865 mm (34 1/16 in.) and 1070 mm (42 1/8 in.) in height measured vertically above a line drawn through the outside edges of the stair nosings. Stairs with 3 risers or less do not require handrails.

In those cases where a stair also requires a guardrail, a reasonable solution is to provide a guardrail which also acts as a handrail, as shown in FIGURE 15.

FIGURE 15 - Combined Guardrail\Handrail

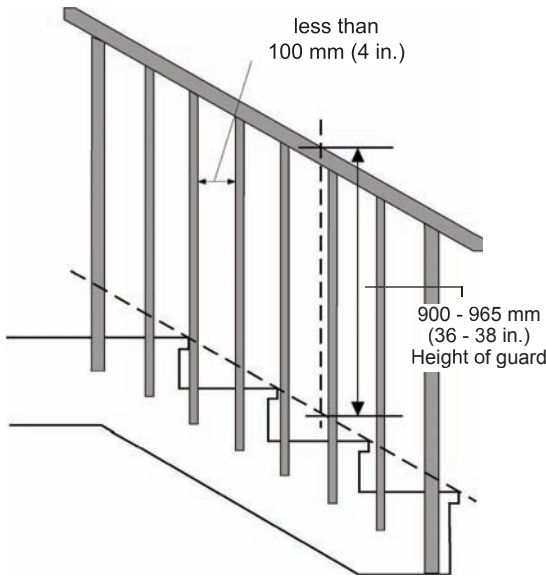

Who enforces all of these requirements?

The City of Steinbach Planning and Zoning Department is assigned the responsibility of monitoring construction for compliance with the various Building Codes and By-Laws. This monitoring is carried out by means of the permit approval process and periodic site inspections.

The ultimate responsibility for compliance rests with the owner and/or contractor.

Is there any way that compliance with a certain aspect of the Building Code can be waived?

Building Inspectors do not have the authority to waive the requirements but it does have the authority to accept alternative solutions which meet the intent of the Building Code. If you feel you can satisfy a Building Code requirement by using an equivalent material or construction method, contact your Building Inspector.

For more information on the regulations for wood decks please contact:

City of Steinbach
Planning and Zoning Department
225 Reimer Avenue
Steinbach, Manitoba
R5G 2J1



Phone: 204.326.9877

Website: www.steinbach.ca

In Person Customer Service Hours are:

Monday to Friday 8:00 a.m. to 5:00 p.m. - All zoning, Permits and Plan Examination services are available at 225 Reimer Avenue.
